

VISION-3

LIGHTING

Stake Mount Ballast **MODEL BM1** 120 Volt, 70 Watt Max.

Specifications:

Housing: Junction housing made from corrosion resistant, thermoplastic PVC, with a black anodized machined 6061-T6 aluminum collar. Housing supplied with three integral 1/2" slip fittings for conduit connection, leak proof cable entry, and feed through wiring. (Conduit and cable not included).

Cap: Available in machined 6061-T6 aluminum, machined C36000 brass, or cast C84400 bronze. Cap contains a 1/2" NPS threaded mounting hole, and is locked to housing collar with three 18-8 stainless steel set screws.

Stem: Stems are machined from 6061-T6 aluminum or C36000 brass, and are threaded 1/2" NPS on both ends. Stem option available in lengths of 3", 6", 12", 18", 24", 30", 36", 42", and 48".

Seals: O-ring groove on ballast cap allows for use of an O-ring to prevent leaking between cap and fixture knuckle. (Note: All Vision3 fixtures come with a high temperature, black Viton O-ring on the knuckle for this purpose). Silicone O-ring between cap and junction collar ensures a watertight junction housing.

Electrical: Three integral 1/2" slip fittings allow for conduit connection, cable entry, and feed through wiring. (Conduit and cable not included).

Ballast: 50/60 Hz 120 Volt input, high power factor, thermally protected electronic metal halide ballast available in 20W, 39W or 70W. Minimum lamp starting temperature: -30°C. Minimum ballast temperature: -15°C.

Finish: TGIC thermo set polyester powder coat paint available in 14 standard colors. On aluminum model, finish is applied over a corrosion resistant, hexavalent chromium free, RoHS compliant coating. Aluminum model available in one additional metal finish: Clear Anodized. Machined brass model available in three additional metal finishes: Natural, Polished, and Aged. Cast Bronze model available in two additional metal finishes: Natural and Aged.

Certification: CSA tested & certified to US and Canadian safety standards for wet location landscape use per UL1598 & CSA C22.2 No. 250-08.

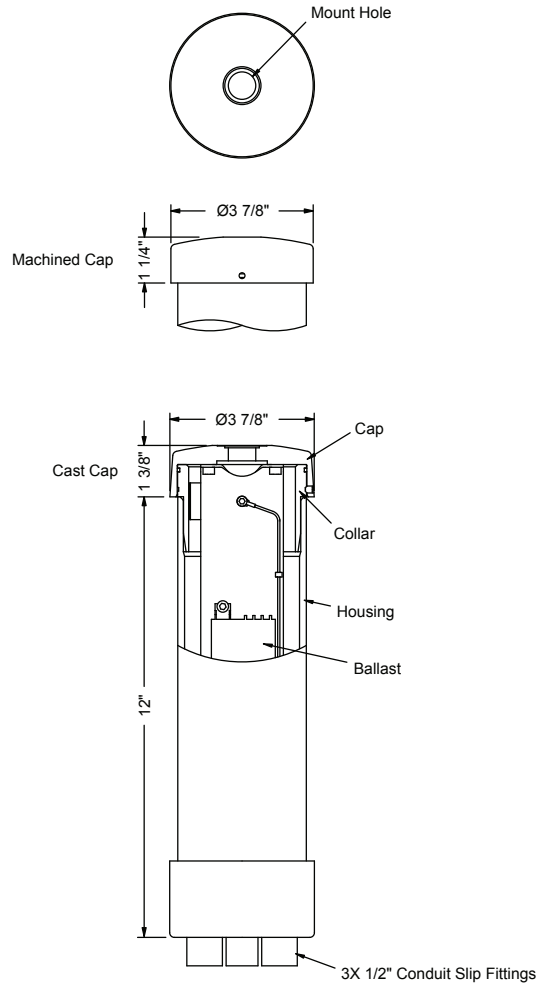

Ordering Information:

Fixture Catalog String ^{1,2}	Model ⁴	Finish	Ballast Type ³	Wattage ³	Voltage	Ignitor	Stem ⁵
	BM1A - Aluminum Cap	BL - Black	E-MH - Electronic Metal Halide	20 - 20 Watts	120 - 120 Volts	ST - Standard	0 - No Stem
	BM1B - Brass Cap (Machined Finish)	BLT - Textured Black		39 - 39 Watts			3 - 3" Stem
	BM1C - Bronze Cap (Cast Finish)	BN - Bronze		70 - 70 Watts			6 - 6" Stem
		BNT - Textured Bronze					12 - 12" Stem
		BAT - Textured Bark					18 - 18" Stem
		WI - White					24 - 24" Stem
		GRT - Textured Green					30 - 30" Stem
		SI - Silver					36 - 36" Stem
		GY - Grey					42 - 42" Stem
		BE - Beige					48 - 48" Stem
		GNT - Textured Granite					
		SAT - Textured Sand					
		PAT - Textured Patina					
		EAT - Textured Earth					
		CLA - Clear Anodized (BM1A only)					
		NAT - Natural (BM1B & BM1C only)					
		POL - Polished (BM1B only)					
		AGE - Aged (BM1B & BM1C only)					

- Notes:**
- Ballast must be specified with an approved Vision3 Lighting metal halide fixture.
 - See fixture submittal for specifications, limitations, and correct catalog number logic.
 - Ballast type and wattage must match fixture lamp type.
 - For a better looking installation, match the model to the fixture it is being used with. Use BM1A with cast or machined aluminum fixtures. Use BM1B with machined finish brass/bronze fixtures. Use BM1C with cast finish bronze fixtures.
 - Because of the machined surface finish on stems, they should only be used with models BM1A and BM1B.
 - Specifications, certifications, and ordering information are subject to change. Please check website for latest specification sheets.

Example: *Fixture Catalog String* - **BM1A - GRT - E-MH - 39 - 120 - ST - 12**